

## CONTINUOUS CASTING PRODUCTS

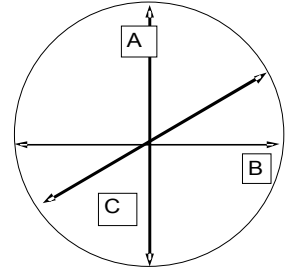

### ROUND SECTIONS

TYPE	REAL SIZE (mm) *			Average arrow max.	Localized arrow max.	Metric weight (kg/m)
	a	b	c			
200	193.5 ÷ 196.5	198 ÷ 200	199 ÷ 201	according to UNI 7063		246
220	216 ÷ 218.5	218 ÷ 221	217 ÷ 221			295
270	266 ÷ 269	269 ÷ 272	268 ÷ 272			455
310	304 ÷ 307	309 ÷ 313	310 ÷ 314			590
405	387 ÷ 393.5	401 ÷ 406	399 ÷ 405			990
500						
600	590 ÷ 595	597 ÷ 602	597 ÷ 602			2200
700	690 ÷ 695	695 ÷ 702	695 ÷ 702			2980

\* average evaluation

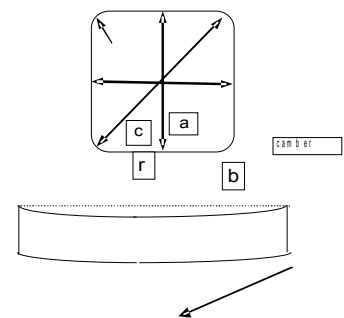

### RECTANGULAR SECTIONS

TYPE	REAL SIZES (mm)*					Metric weight (kg/m)
	a	b	c	r	camber	
240 x 200	238 ÷ 242	198 ÷ 200	239 ÷ 241	14	conf. a UNI 7063	379

\* average evaluation

GUARANTEE: "UNI 8768" AND "UNI 7063" (+-5% ON SIDE and CAMBER 20 mm/m LOCALISED DEF. and 10 mm/m AVERAGE DEF.)

Warping: UNI 7063=4°/m with 15° max for lengths ≤6 m and 20° max for lengths > 6 m

Obtainable lengths : min. 4,000 mm, max. 12,000 mm with 100 mm cutting allowance.